

MODEL 487-0XX ELECTRONIC VACUUM / PRESSURE REGULATOR INSTALLATION INSTRUCTIONS

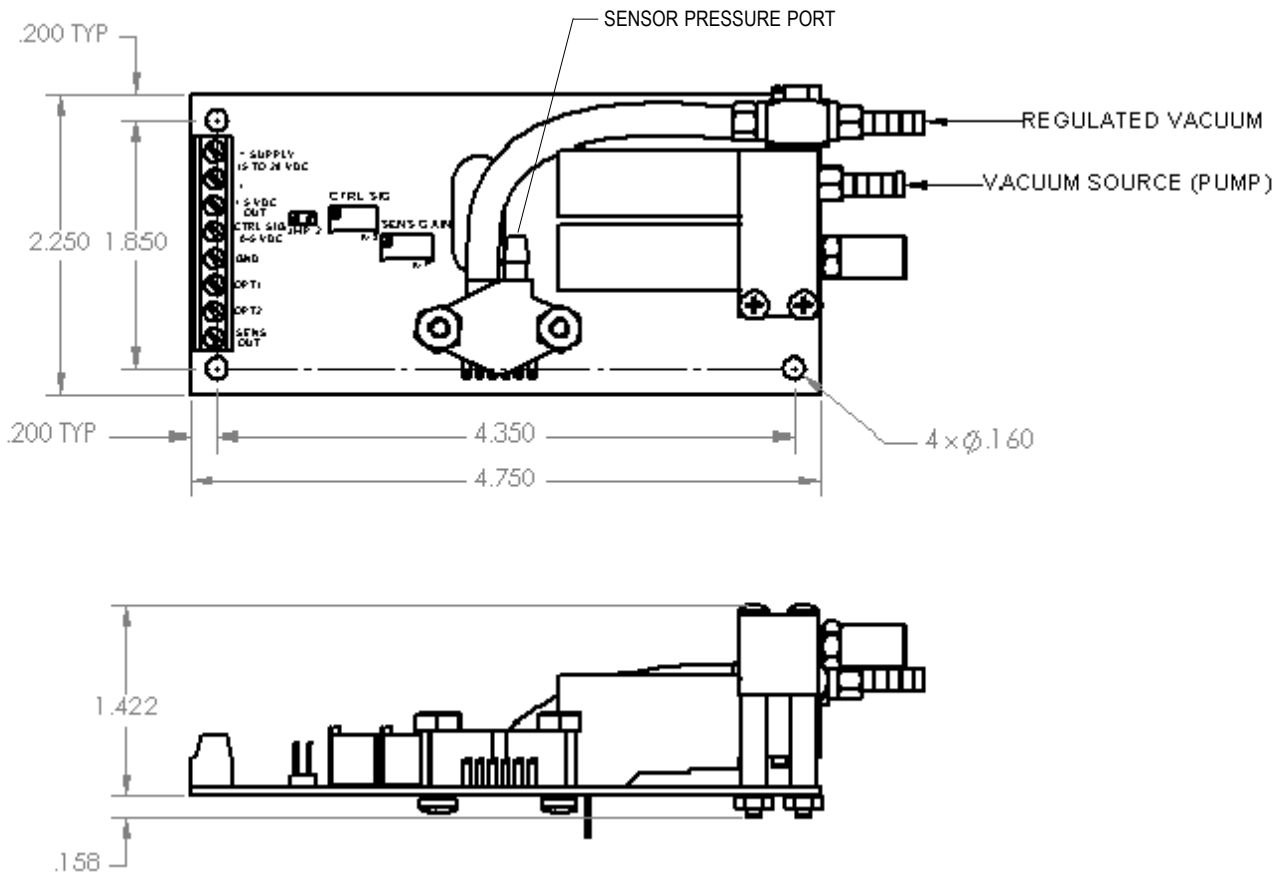

All mounting dimensions are in inches with a tolerance of $\pm .015$

Note:

1. The board assembly must be mounted on standoff supports to provide a minimum of 1/4 inch clearance between the board surface and mounting surface. Conductive materials must not touch the bottom of the board, since they could short out components and damage the board and/or "control signal" generating source. The board should be installed inside an enclosure to prevent contact by people and objects with the electrical components. The user-furnished DC power supply must be capable of providing 250 mA of current.
2. The user has a number of options for generating the "control signal" used to set the vacuum level of the regulator. An analog control voltage source can be provided from a user-supplied control system or computer. If desired, the user can connect a 5K or 10K ohm, single-turn or multi-turn, potentiometer to the signal connector, which will then use the 5-volt supply provided within the board. Alternately, the user can choose to use the 25-turn potentiometer already installed on the board and labeled R18 (CTRL SIG) in place of adding a separate potentiometer. Jumper JMP2 must be installed to utilize the on-board potentiometer. The board-mounted potentiometer is only intended for occasional adjustment due to its small, plastic construction/design. Board mounted potentiometer use should be limited to applications which only require occasional adjustment, such as initial setup and/or periodic calibration or adjustment of the vacuum setting.
3. A hose connection from the "vacuum source" must connect to the port (brass barb) as shown above. All vacuum connections should be made with 1/8 inch inside diameter flexible rubber or polyurethane hose. The "vacuum regulated" port (brass barb) connects to the user's regulated vacuum system or chamber. The hose that connects between the regulated vacuum port and vacuum chamber should be as short as possible. If the required hose length is greater than a foot, then a larger diameter hose should be used to minimize the effect of pressure transients within the hose which can reduce the regulator's ability to control.

Pressure Regulator Operation

The regulator can be configured to regulate pressure instead of vacuum by connecting to hose to the other pressure port of the sensor and connecting the vacuum supply to a pressure source. Note one port of the pressure sensor is always left open to atmosphere. The maximum pressure that can be regulated is limited by the sensor installed on the board. To configure for pressure regulation the supply pressure, which should not exceed 30 psi should be connected to the valve in place of a vacuum source. Change the connection to the pressure port of the pressure sensor. Be careful when removing the hose to prevent damage to the barb on the sensor. Any nick or damage to barb can result in leakage. One method to remove the hose is to gently pull on the hose while twisting back and forth. Also gently pushing against the back edge of the hose with a knife blade or screwdriver will help in hose removal.

Vacuum Regulator Scale Adjustments

The ratio of control signal voltage to regulated vacuum is set by the adjustment of potentiometer R17 (SENS GAIN). Adjusting R17 will also influence the maximum vacuum level attainable. All assemblies are adjusted at the factory to a preset level as defined by the model number. If a user desires to rescale the unit for a different control signal level, the following procedure should be followed:

1. Jumper positions must be set as required for the type of control input desired, i.e., on-board potentiometer or control signal. A vacuum gauge will be required to measure the vacuum level and to determine the full scale vacuum setting. During the calibration/adjustment procedure, ensure that only a minimum amount of leakage is present in the system and that the vacuum pump/source is capable of maintaining the maximum desired vacuum. Also ensure that the flow limitation of the valve is not exceeded, since inaccurate scaling will result if flow is being limited by the maximum flow capacity of the valve thereby preventing the system from reaching the desired full vacuum setting. The open air flow rate through Model 487-XXX-Y is based on the "-Y" in the part number: -1 is 5 SCFH (standard cubic feet per hour), and -6 is 25 SCFH (all measured with 14 psi differential across the valve).

2. Apply the maximum desired control signal up to 4.9 volts maximum or set either the on-board or user supplied potentiometer at its maximum setting. Then adjust R17 to produce the desired full scale vacuum (or pressure if used as a pressure regulator). Note that the vacuum level changes as R17 is adjusted, therefore it is important to ensure that leakage in the system does not exceed the flow capacity of the valve as mentioned in paragraph 1 above. The vacuum level must not be exceed the capacity of the pressure sensor, which is 1.5 psi (41 inches-water) for P/N 487-001 which uses the MPX5010 sensor and 15 psi (30 in. Hg) for P/N 487-002 which uses the MPX5100 sensor. Control signal values and potentiometer settings of less than full scale will produce reduced vacuum levels in proportionate ratios. Typical vacuum versus control voltage curves for both models are shown below

Vacuum vs. Volts Model 487-001

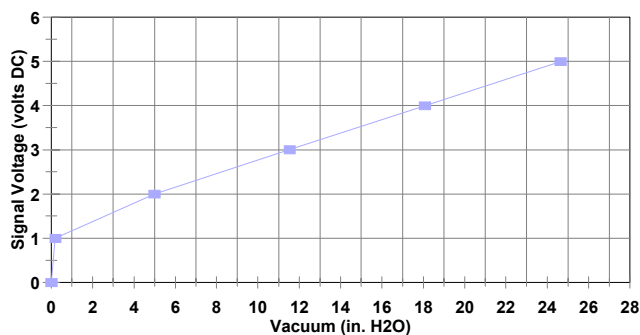

Vacuum vs. Volts Model 487-002

